



# OUR PRODUCT OVERVIEW

**WELCOME TO  
AAKRUTI PROCESS TECHNOLOGIES PVT LTD**

---

**We are equipment manufacture for Food, Chocolate, Dairy & Pharmaceutical industries meeting the highest standards of quality, design and specification.**

[www.aakrutiprocess.com](http://www.aakrutiprocess.com)



## **OUR MISSION**

**Our Mission to deliver state-of-the-art piping, structural, and automation solutions that empower manufacturers in the food, pharma and chemical industries to achieve excellence and maintain a competitive edge.**

## **OUR VISION**

**Our Vision to be the global leader in providing advanced, reliable, and eco-friendly manufacturing solutions for the food, pharma and chemical sectors**

## **OUR VALUES**

**Our Values are committed to delivering excellence, innovation, and sustainability in every project. Our core values of integrity, quality, and customer satisfaction drive us to lead in pneumatic conveying and bulk material handling solutions**

# KEY PERSON



**NIRAV PATEL**  
**CEO & FOUNDER**

**With over 20 years of experience in the food processing industry, Nirav Patel has led numerous turnkey projects from concept to commissioning. His expertise spans process design, equipment manufacturing, automation, and plant optimization. Under his leadership, the company has grown into a trusted name for delivering innovative and efficient food processing solutions across multiple sectors. Nirav Patel Leading the organization with strategic insight and industry excellence**



## TEAM AAKRUTI

**A Aakruti Process Technologies Private Limited Withextensive hands-on experience in the food processing industry, I have developed strong expertise in process design, equipment selection, and end-to-end plant operations. My background covers a wide range of food categories including spices, grains, pulses, ready-to-eat products, nutraceuticals, and specialty ingredients. Over the years, I have been actively involved in concept development, process optimization, quality improvement, and automation integration to enhance productivity and ensure consistent product quality. My work spans critical areas such as sieving, mixing, roasting, grinding, conveying, storage, cleaning, and packaging systems. I have collaborated closely with R&D, production, and engineering teams to deliver efficient, hygienic, and cost effective processing solutions while complying with industry standards and food safety guidelines. This well-rounded experience enables me to support projects from initial layout planning to successful commissioning and performance validation.**

## OUR INFRASTRUCTURES

**We are supported by a well-developed infrastructure equipped with modern facilities and advanced machineries. Our manufacturing unit is designed for efficient production, strict quality control, and timely execution. With skilled manpower, in-house fabrication, testing, and finishing facilities, we ensure reliable performance, precision engineering, and consistent product quality.**



**PULSE JET FILTER**



**BAG CLAMPING**



**BUCKET ELEVATOR**



**CYCLONE SYSTEM**



**BUTTERFLY VALVE**

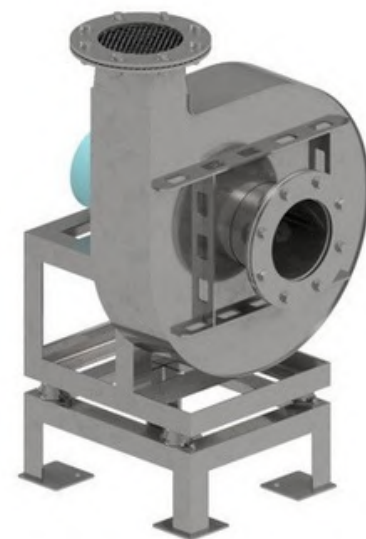

**CENTRIFUGAL FAN**



**CONE MILL**

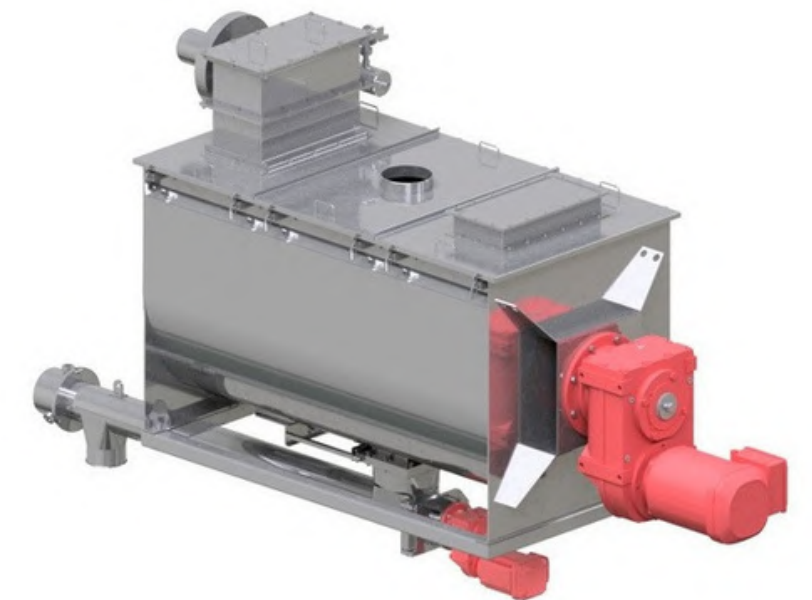

**COOLING MIXER**

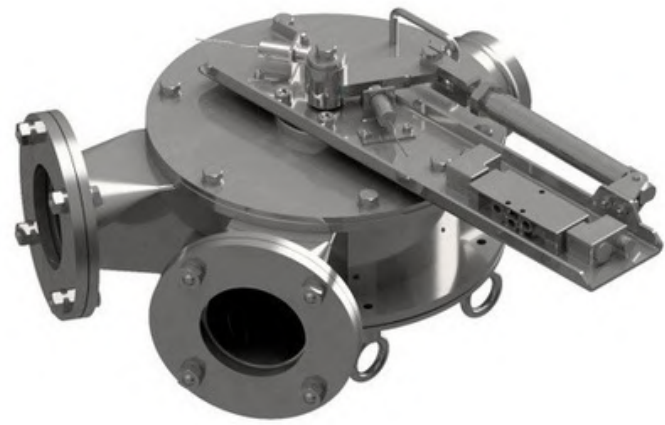

DUAL TUNNEL  
DIVERTER VALVE



FILTER BAG



FILTER STRAINER



IBC DISCHARGE  
STATION

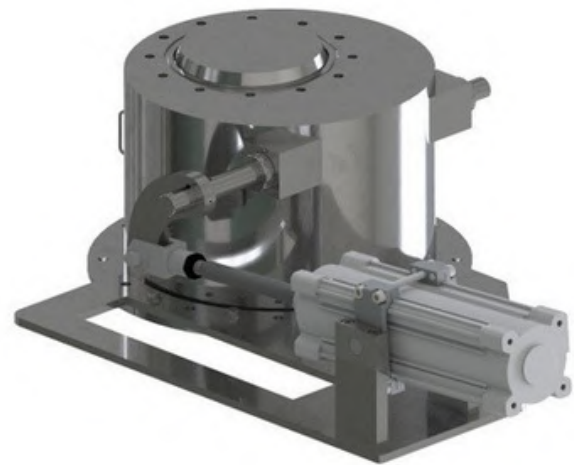

FLUSH BOTTOM VALVE

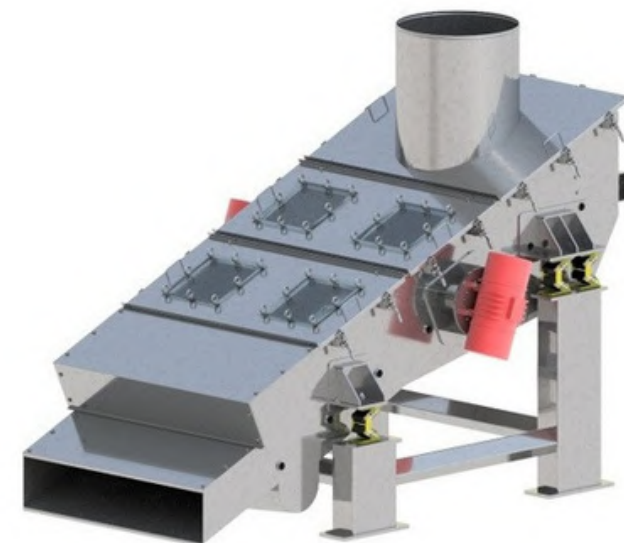

GRADER  
VIBRO SCREENERS

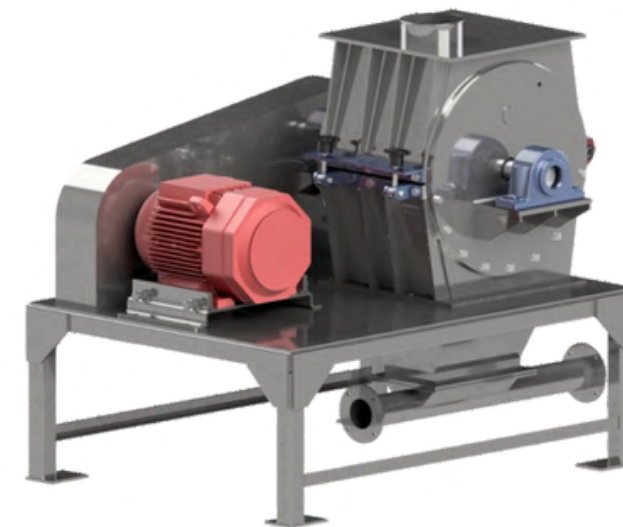

HAMMER MILLS



HOPPER FOR POWDER



INCLINED SCREW  
CONVEYOR



KNIFE GATE VALVE



OIL DOSING TANK



PULSE VALVE

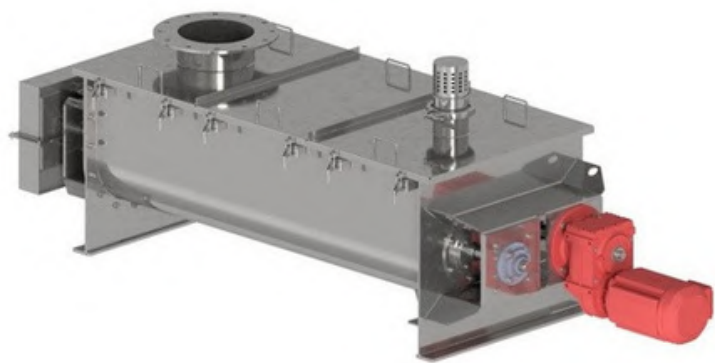

PADDLE MIXER



PERMANENT MAGNETIC  
SEPRATOR



PIPING

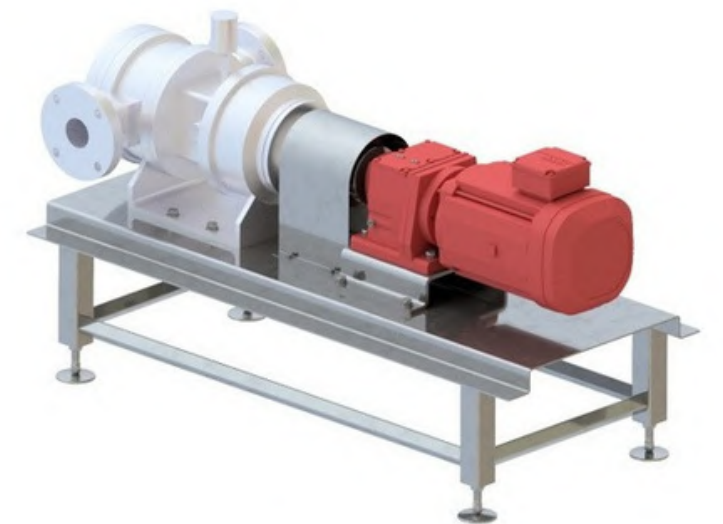

PUMP



ROASTER MACHINE



ROTARY  
AIRLOCK VALVE



ROTARY SIFTER



SIGHT GLASS



VIBRO SCREENER



SACKTIP STATION  
WITH VIBRO SIEVE



SCREW FEEDER



SCREW FEEDER  
WITH VALVE

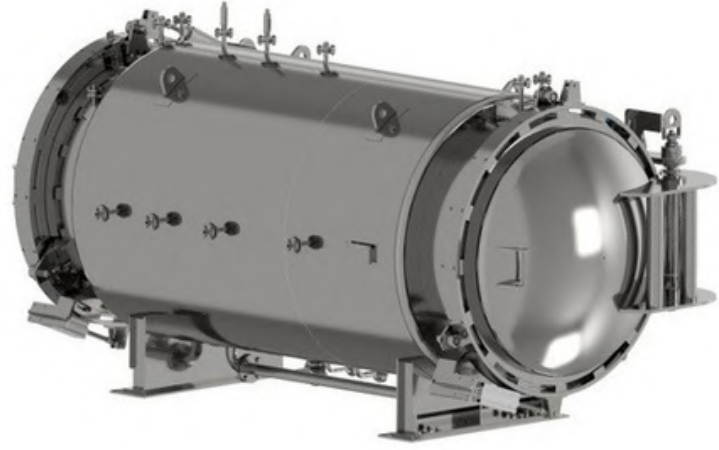

STEAM STERILIZER



STORAGE SILO  
WITH BIN ACTIVATOR



STORAGE SILO



VERTICAL MIXER

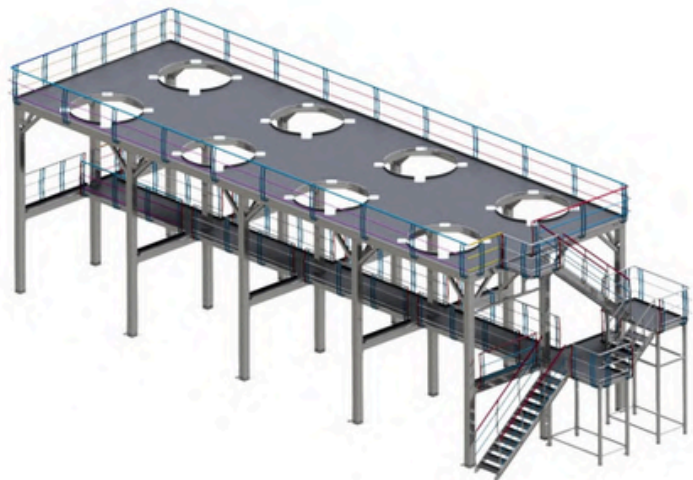

STRUCTURE

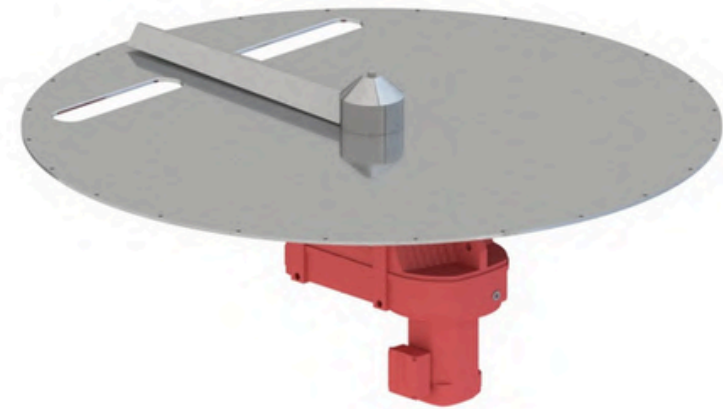
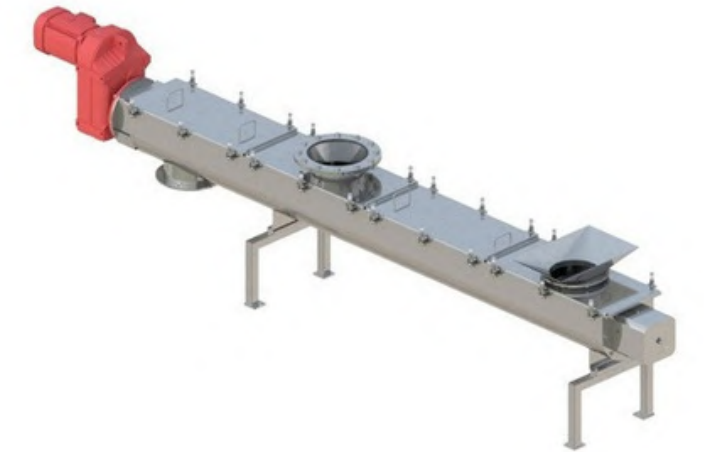

TABLE FEEDER



TIPPING STATION



U TYPE HORIZONTAL  
SCREW FEEDER



**VIBRO SCREENER  
RECTANGULAR**



**WEIGHT FEEDER**



**CONTROL PANEL**

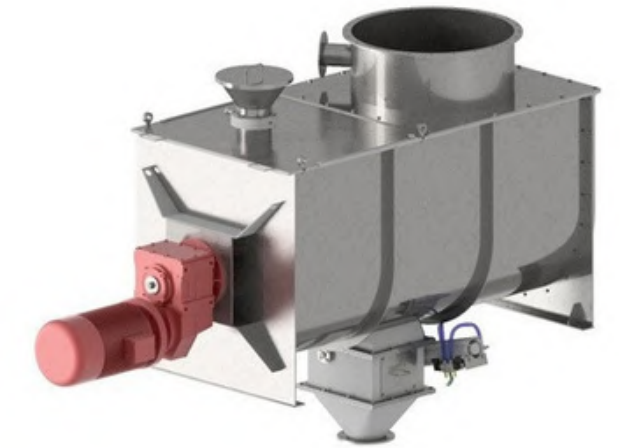

**RIBBON BLENDER**

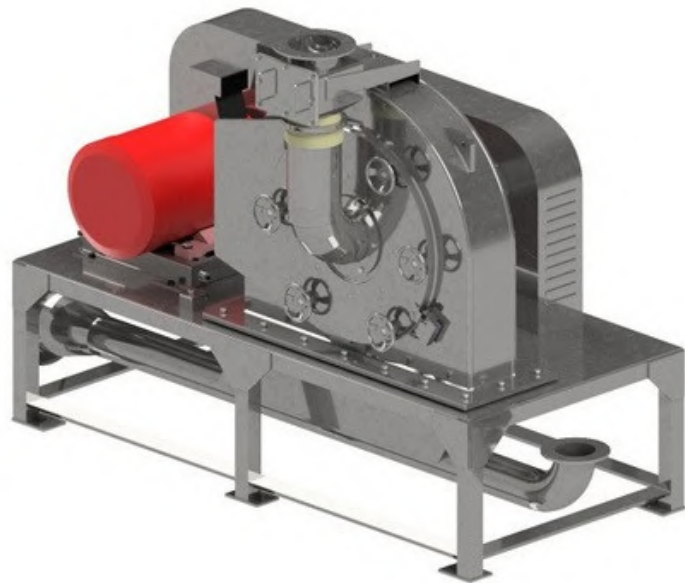

**UNIVERSAL MILL**



**SPICE HAMMER MILL**

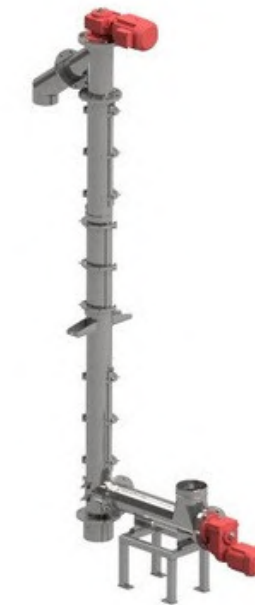

**VERTICAL SCREW  
ASSEMBLY**



**DRAG CHAIN  
CONVEYOR**



**FINE SAVER**



**HOT WATER TANK**



**PIN MILL**



**ROLLER CONVEYOR**



**BELT CONVEYOR**

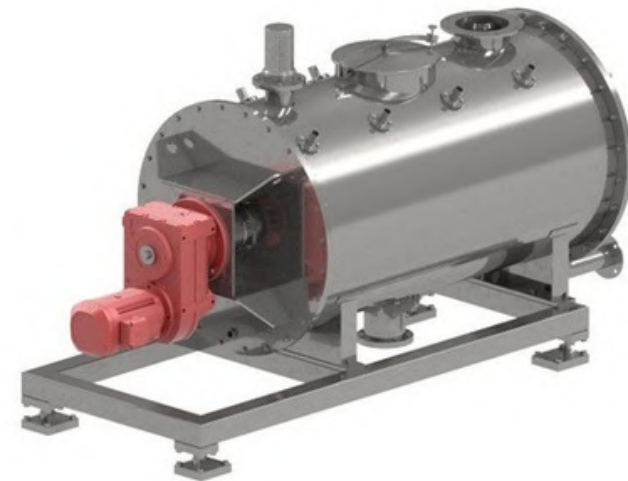

**ROUND TROUGH  
MIXER**



**SACKTIP STAION WITH  
VIBRO SCREENER**



**SUGAR GRINDING**



**INLINE STRAINER**



**BUTTER TANK**



**MILK COOLER**



**CONDENSOR**



**NUTS  
DEPUMPING SYSTEM**

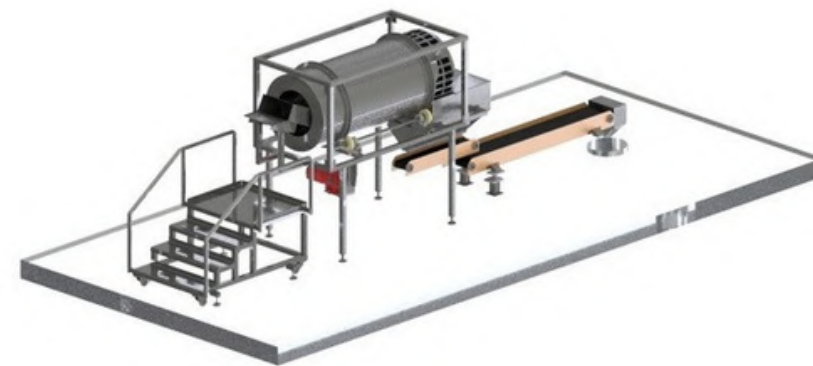

**NUTS HANDLING  
SYSTEM**



**COOLING TUNNEL**



**HORIZONTAL  
STEEL BELT CONVEYOR**



STORAGE TANK



BLOCK MELTER

# RAW MATERIAL HANDLING SYSTEM

**A APT Make A Raw Material Handling System is designed to receive, store, convey, weigh, and feed raw materials safely and efficiently to different stages of a production process. It ensures smooth material flow, reduces manual handling, minimizes material loss, and improves productivity in food, chemical, pharmaceutical, and allied industries.**

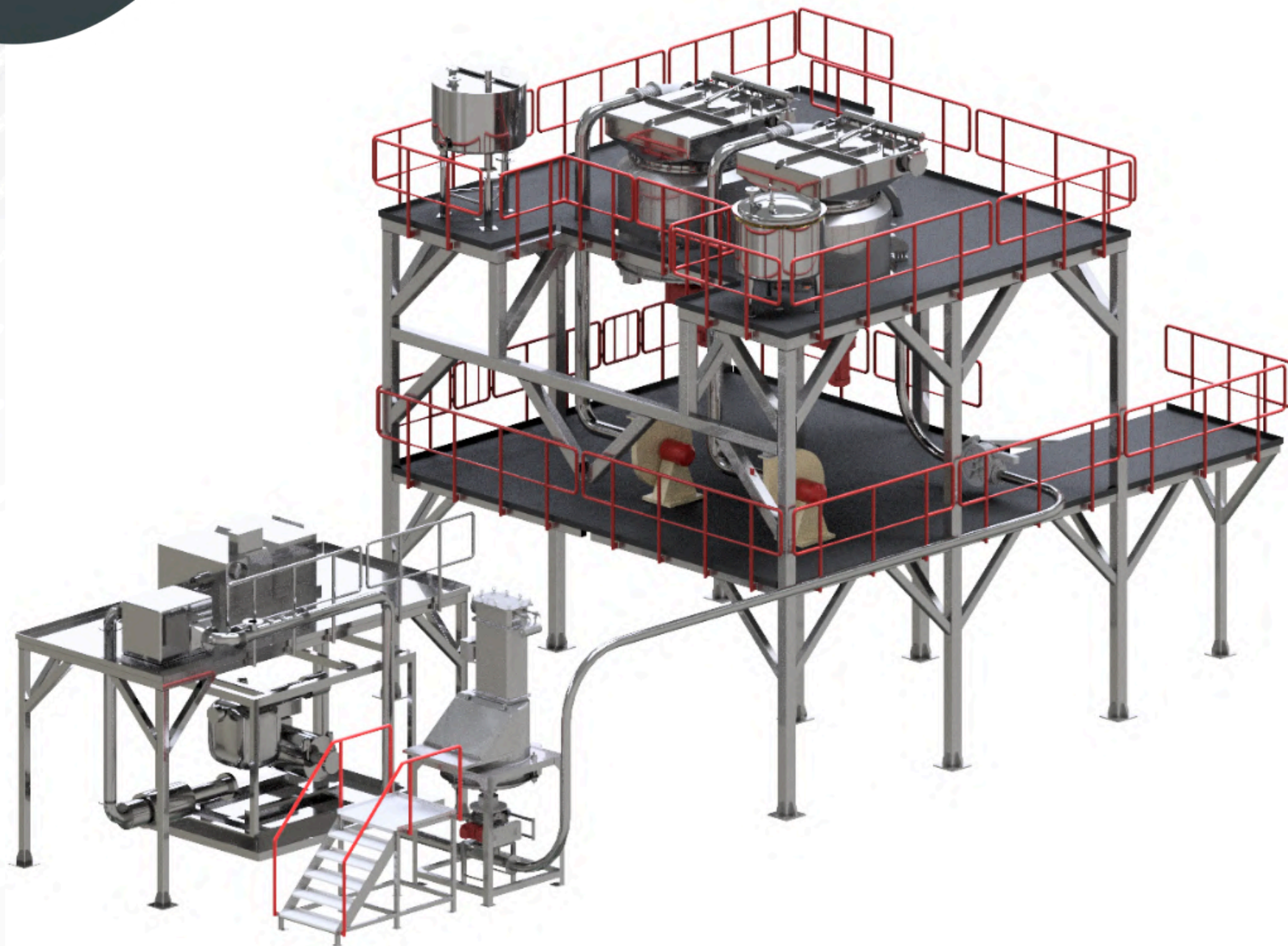

# SUGAR GRINDING SYSTEM

**A APT Make Sugar Grinding System is designed to convert crystal sugar into fine powdered sugar with uniform particle size. The system typically includes a grinder or pin mill, feeding mechanism, dust-free conveying, and a sieving unit to ensure consistent fineness. It is widely used in food, confectionery, bakery, and pharmaceutical industries for hygienic, efficient, and continuous sugar powder production.**



# SPICE GRINDING SYSTEM

**A APT Make A Spice Grinding System is a complete processing setup used to clean, dry, grind, and sieve whole spices into fine or coarse powder. The system ensures uniform particle size, high aroma retention, minimal heat generation, and hygienic processing. It is widely used in spice, food, and masala industries for consistent quality and high production efficiency.**



# PRECISION ENGINEERING FOR FOOD, PHARMA & CHEMICAL

## BEST SOLUTIONS FOR FOOD, PHARMA AND CHEMICAL

We are a leading manufacturer of high-quality equipment for spice and confectionery plants. With a deep understanding of the industry and a commitment to innovation, we provide state-of-the-art machinery designed to enhance efficiency, quality, and sustainability in your production processes.

# INDUSTRIES WE SERVE

## FOOD

SNACKS, FLOUR, BAKERY, GRAIN

## CONFECTIONERY

## SPICE

SEASONING, SAUCES

## PETROCHEMICALS & SPECIALTY CHEMICALS

## DAIRY

MILK, CHEESE, BUTTER, YOGURT

## PHARMACEUTICALS

BULK DRUGS / API / INTERMEDIATES

# OUR CLIENTS

Proudly trusted by leading brands across the food, pharma, chemical and engineering industries





## FIND US ON



LINKEDIN



WEBSITE



YOUTUBE

[www.aakrutiprocess.com](http://www.aakrutiprocess.com)

### HEADQUARTERS

Survey No. 60 Near Haripura Village,  
Mepro-Haripura Road, Jarod-Savli Road,  
Jarod - 391520, Dist. Vadodara, Guajrat, INDIA

### CONTACT

NIRAV PATEL  
+91 8200795832  
+91 8511217722

### EMAIL

ceo@aakrutiprocess.in  
sales@aakrutiprocess.in



PROCESS TECHNOLOGIES PRIVATE LIMITED

**THANK YOU**

[www.aakrutiprocess.com](http://www.aakrutiprocess.com)